

**CLASS 1 TRAILER HITCH**

**RT-856**

Saturn Astra

**TOOLS REQUIRED:**

DRILLS: NONE

WRENCHES: 11/16"

**2,000 LB GROSS TRAILER WEIGHT, 200 LB TONGUE WEIGHT. WARNING: CONSULT VEHICLE OWNERS MANUAL FOR TOWING RECOMMENDATIONS AND LIMITATIONS. THIS PRODUCT IS DESIGNED FOR TRAILER TOWING ONLY AND SHOULD NOT BE USED FOR ANY OTHER PURPOSE.**

**WARNING: USE ONLY RIGID HITCH APPROVED AND MANUFACTURED DRAW BAR INSERT OR WARRANTY WILL BE VOID**

NOTE: INSTALL PARTS LOOSELY UNTIL ALL ATTACHMENTS HAVE BEEN MADE TO VEHICLE

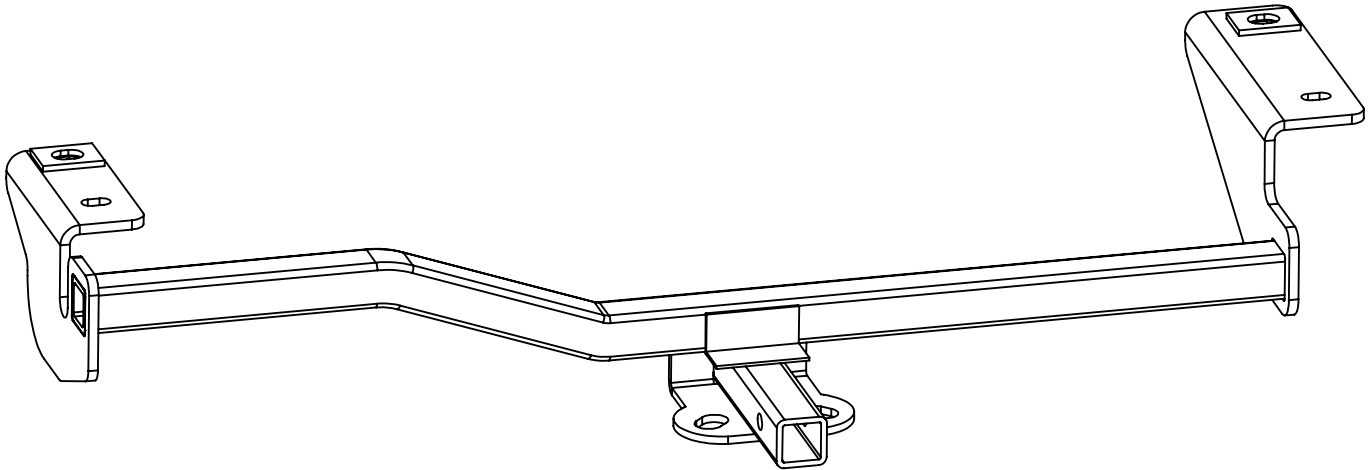

1. Temporarily lower exhaust by removing 2 studs from rubber isolators.
2. Raise hitch into place making note of attachment holes that align with slots in hitch side brackets.
3. Lower hitch. Using fish wires provided fish (4) 7/16" carriage bolts and (4) 1 x 3 block plates into frame rails through large access holes and down through the noted attachment holes.
4. Using care not to push the carriage bolts back into the frame, raise the hitch into place and secure with conical washers and hex nuts provided.
5. Use a torque wrench to tighten all fasteners to the appropriate specifications shown below.
6. Raise exhaust back into place and reinstall the 2 studs removed in step 1.

**Thank you for purchasing a Rigid Hitch**

**TIGHTEN ALL FASTENERS TO THE TORQUE SPECIFICATIONS SHOWN BELOW**

**Hardware Package:**

(4) 7/16 - 14 x 1 3/4" Carriage Bolts  
 (4) 7/16" Conical Washers  
 (4) 7/16 Hex Nuts

(4) 1/4 x 1 x 3" Block Plates  
 (2) 7/16" Fish Wires  
 (1) UB-6001 Draw Bar Kit

**GIVE THIS INSTRUCTION SHEET TO VEHICLE OWNER**

<b>BOLT TIGHTENING TORQUE (LB-FT)</b>			
<b>BOLT SIZE</b>	<b>TORQUE</b>	<b>BOLT SIZE</b>	<b>TORQUE</b>
3/8"	25 LB FT	8MM	20 LB FT
7/16"	50 LB FT	10MM	38 LB FT
1/2"	60 LB FT	12MM	68 LB FT
3/4"	120 LB FT		

**THIS PRODUCT COMPLIES WITH SAFETY SPECIFICATIONS AND REQUIREMENTS FOR SAE AND VESC REGULATION V-5 FOR CONNECTING DEVICES AND TOWING SYSTEMS. DO NOT MODIFY THIS PRODUCT. INSTALL ONLY ON SPECIFIED VEHICLES IN GOOD CONDITION.**

**RIGID<sup>®</sup>**  
**HITCH INCORPORATED**  
 3301 WEST BURNSVILLE PARKWAY  
 BURNSVILLE, MN 55337  
[www.rigidhitch.com](http://www.rigidhitch.com)

REV.  
7/08